



## Polyphase electromechanical electricity meters



The type series ET 32. and ET 42. polyphase electricity meters are designed for electric energy measurement in three-phase systems in house services, industrial premises as well as in distribution networks with frequency of 50 or 60 Hz, reference voltage up to 500V and balanced or unbalanced loading. The meters are available for both direct and indirect ways of connection, and both watthour (active energy measurement) version. The meters are of the induction type and of accuracy classes 2 or 1 according to IEC/EN 62052-11, IEC/EN 62053-11 Standard Specification (watthour-meters) and meet also the requirements of other standards derived from IEC. Current and voltage ranges and the meter case's types are delivered in accordance with demands of the customer.

# ET 32./ET 42.

# ET 32. /ET 42.

**The measuring assembly** comprises two (ET 32.) or three (ET 42.) driving elements, a braking element, a two-disc rotor with bearings, a register and a mounting frame where all components are fixed. The driving element of the first phase and the braking element always carry the upper disc, the lower disc is from the front carried by the second driving element (ET 32.) or from both sides by the second and the third driving elements (ET 42.). The symmetrical location of the driving elements and polarity of their coils eliminates the influence of reversed phase sequence on meter errors. The wide measuring range is achieved by efficient disposition of magnetic flows in the air gap, and by using of the magnetic shunts on the current frames.

**Register.** The register for single rate is of 6-digits or 7-digits cyclometric type and can be fitted in two versions differing by dimensions of the number wheels and its numerals, small drums made of plastic (6 or 7 numerals dial, numerals size 5 x 2.8 mm) and bigger plastic drums (6 numerals dial, numerals size 7.5 x 4.5). The register position on the frame is secured by adjustable stop end so that with removing and replacing the register the mesh between the worm on the rotor shaft and the worm wheel will not change its original setting. With the quick change transfer the reading changes in one jump what prevents the register from appearing of the part of true numerals, the reading is always unambiguous. The two-rate register is made with plastic wheels with numerals size (5 x 2.8) mm as 6-digits or 7-digits.

**The case with terminal block.** The all-insulated case comprises phenolic moulded base of uniform dimensions up to maximal current of 120 A. The cover may be moulded of black phenolic resin with a glass window or whole made of transparent

polycarbonate. The terminal block cover is available of black shock-proof polystyrene or of transparent or black polycarbonate. The meter cover is fitted by three captive screws and the terminal-case cover is fixed by two ones. The all-insulated version meets all safety requirements of the double insulation level. The contact surface between the base and the cover is protected against dust and extraneous objects penetration by an elastic gasket of porous rubber. The glass window of the cover is blinded by cementing paste.

The terminal-block covers are short or of the prolonged type of various length depending on the current rating. The terminal-block covers for higher ampere ranges are larger to provide more space for the cables. The extended terminal-block covers are also available with openings for the cables at the bottom for installation onto the wall or onto the switchboard. The wiring diagram is located on the internal side of the terminal cover or printed on the name plate. The terminal block is composed of a bakelite, bush-type current terminals inserted into the body and they suit to the reliable connection of both copper and aluminium cables. Deep cone-shaped cable entries into the insulating material of the terminal-block body are provided to facilitate the connection of both stranded and solid cables and to cover their insulation parts. Ample anticreepage partitions are provided between terminal groups of different phases. The terminal block is rigidly fitted with the meter base and sealed. The diameter of drilling of terminals is 6, 7, 8, 9, 10 mm for direct connection and 5 mm for indirect connection.

## Load curves

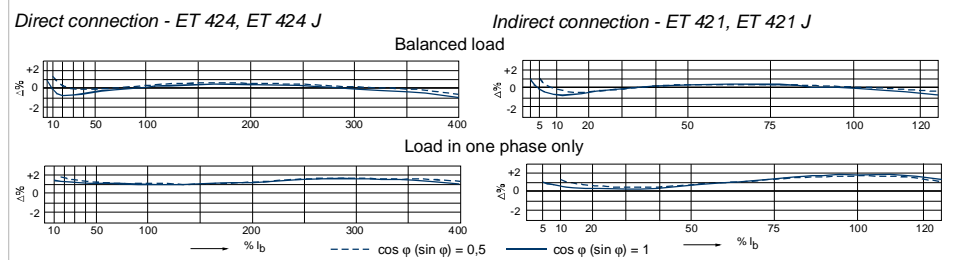

## Average values of additional errors

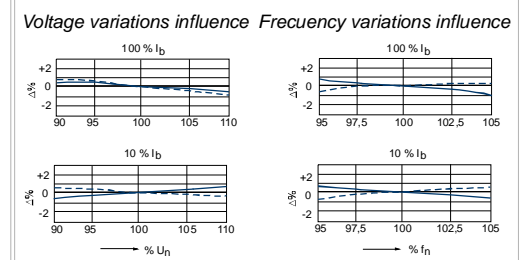

## External connection diagrams Type of meters ET A2BCDFGH1JKLM

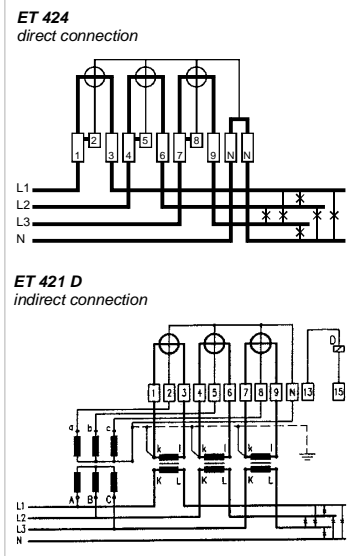

- ET - three-phase electricity meter (no mark) current terminal connection according with DIN, BS
- A 3 - 3-wire meter with two driving systems
  - 4 - 4-wire meter with three driving systems
  - 2 - type series
  - B - overload capacity
    - 1 - 120%  $I_n$
    - 4 - 400%  $I_b$
    - 5 - 500%  $I_b$
    - 6 - 600%  $I_b$
    - 7 - 700%  $I_b$
    - 8 - 800%  $I_b$
  - C - (no mark) for active energy - 2.0
  - D - reg. with plastic wheels with num. dim. (5.0x2.8) mm
  - H - reg. with plastic wheels with num. dim. (7.5x4.5) mm
  - F D - two-rate register (only LD)
  - R - reversible mechanism (integrating only additions)
  - F - "HF" register with quick change transfer (Fast)
  - G F - register with quick change transfer (HF)
  - R - reversible mechanism (HR)
  - H 7 - register with max. 7 wheels
  - 6 - register with max. 6 wheels
  - 1 - register with max. 6 or 7 wheels
  - 0 - special version in accord. with customer's demands
  - 1 - bakelite base (separated terminal block up to 120 A)

- J 1 - black bakelite case with glass window
- 2 - transparent polycarbonate case
- K 1 - black polystyr. therm. block case (to 60 A, 120 A)
- 2 - transp. prolonged polycarb. therm. block case
- 5 - transparent short polycarb. therm. block case
- 7 - black polycarb. therm. block case (to 60 A, 120 A)
- B - bakelite terminal block case (to 100 A)
- L 32 - 150/230 mm, bakel.all-insulated base (to 120 A)
- 34 - 150/210 mm, bakelite base for direct electricity meter (to 120 A)
- 44 - 150/215 mm, bakel. all-insulated base (to 120 A)
- 45 - 150/245 mm, bakel.all-insulated base (to 120 A)
- M z - reverse-running stop
- i - internal link between voltage and current circuits
- u - lower magnetic bearing
- l - prolonged terminal block case
- c - shortened terminal block case
- h - hidden suspension
- c - tipping handle
- o - large window of meter case
- e - encapsulated voltage coil

## Technical data

Accuracy class - for active energy	2.0
Reference voltage	3x230/400; 3x240/415; 3x400; 3x230 V, 3x57,7/100; 3x127/220; 2x120 V
Current rating - direct connection - $I_b$	5; 10; 15; 20; 25; 30 A
- $I_{max}$	20; 30; 40; 60; 80; 100; 120 A
- indirect connection - $I_n$	5; 1; 1.5 A
Mains frequency	50 Hz, 60 Hz
Maximum power of voltage circuit	1 W/4.8 VA (1.1W/5.2 VA)
Maximum power of current circuit	0.94 W/1.2 VA
Average temperature coefficient - active energy	$\cos \varphi = 1 < +0.05 \% / ^\circ C$ , $\cos \varphi = 0.5 < -0.08 \% / ^\circ C$
Numbers of rates	1 or 2
Weight	maximum 3.5 kg
Coverage	IP 51

## Dimensional Drawing

